

PERMITS

A permit is required for an accessory building with **any** dimension greater than 12'-0" (12 feet).

The first step in building an accessory building should be to obtain the proper **Zoning** and **Building** permits.

FOUNDATION

Accessory buildings may be constructed without masonry or concrete foundation provided all the following conditions are met. As follows;

1. The accessory building shall not exceed 400 square feet.
2. The accessory building shall not exceed one (1) story in height.
3. The accessory building is supported on wood foundation of a minimum 2"x6" or 3"x4" mud sill of approved wood in accordance with section 323 of the NC Residential Code.
4. The accessory building shall be anchored to resist overturning and sliding by installing a minimum of one (1) ground anchor at each corner of the accessory building. The total resisting force for all anchors shall be equal to 20 psf times the plan area of the accessory building.

NOTE: See *Anchoring Detail*.

The building inspector is then called out to look at the following items:

1. The inspector can inspect the building after all construction has been completed provided the interior of the accessory building has not been finished. The studs and rafters must be visible for inspection.

ANCHOR TIE DOWN DETAIL

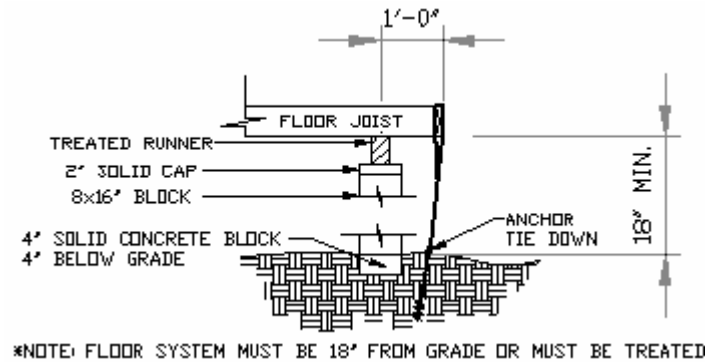

FLOOR JOIST SPANS FOR SOUTHERN PINE # 2

Joist Size	Spaced @	Will Span	Joist Size	Spaced @	Will Span
2 x 6	12" OC	10' 9"	2 x 10	12" OC	18'
	16" OC	9' 9"		16" OC	16' 1"
	24" OC	8' 6"		24" OC	13' 1"
2 x 8	12" OC	14' 2"	2 x 12	12" OC	21' 9"
	16" OC	12' 10"		16" OC	18' 10"
	24" OC	11'		24" OC	15' 4"

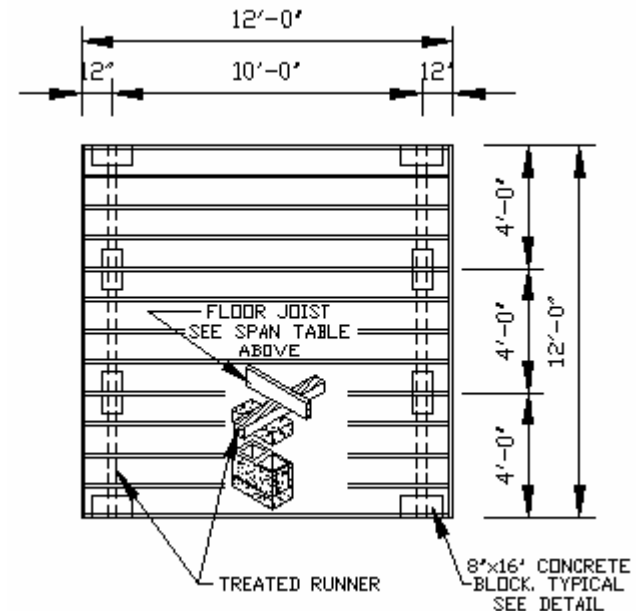

FLOOR PLAN

INSPECTION DEPARTMENT CONTACTS

ASHEBORO OFFICE

Paxton Arthurs (Director) – 336-318-6560
Melissa Burkhart (Office) – 336-318-6578
Jennifer Garner (Office) – 336-318-6595
Debbie Thompson (Office) – 336-318-6577
David Bryant (Plan Review) – 336-318-6366
John Hancock (Electrical) – 336-318-6579
Dave Hawk (Electrical) - 336-318-6562
Bobby Everhart (Electrical) – 336-318-6567
Brian Heilig (Plumb/Mech) – 336-318-6363
Danny Keye (Plumb/Mech) – 336-318-6580
Danny York (Plumb/Mech) – 336-318-6563
Ronnie Cranford (Building) – 336-318-6564
Jeff Stout (Building) – 336-318-6582
Brian Underwood (Building) – 336-318-6566

FAX: 336-636-7574

**GUIDELINES FOR BUILDING AN
ACCESSORY BUILDING
UP TO 400 SQUARE FEET**

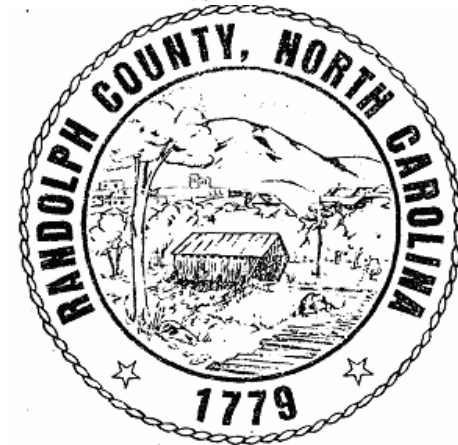
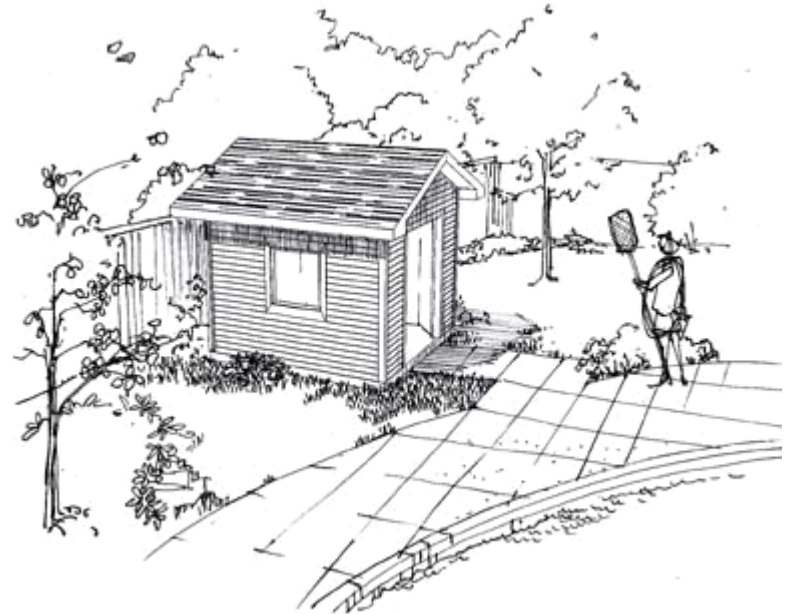

**RANDOLPH COUNTY
DEPARTMENT OF BUILDING INSPECTIONS**